

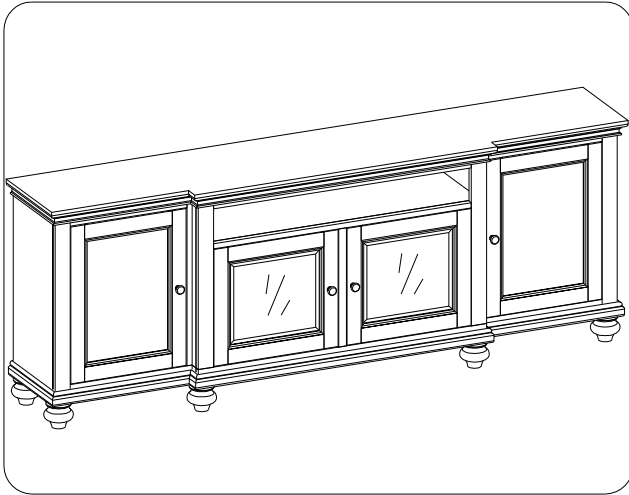

ITEM NO: I07-284-WBR/PEP/BLK 86" Console

Thank you for purchasing this quality product. Be sure to check all packing material carefully for small parts that may come loose inside the carton during shipment.



TOOLS REQUIRED (NOT PROVIDED)			
PHILLIPS SCREWDRIVER			
COMPONENTS LIST:			
No.	Description	Sketch	Quantity
1	Bun Foot		6 PCS
2	Support Leg		2 PCS

**STEP 1:** Put the console upside down on a soft surface, Attach the bun feet and support legs to the case. Turn the console to the upright position.

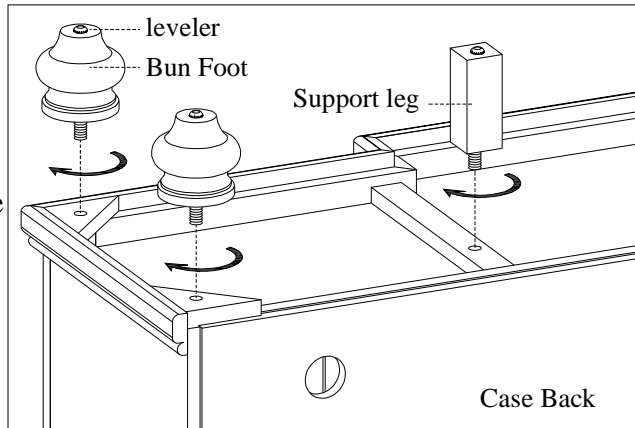

### FUNCTIONALITY INSTRUCTION

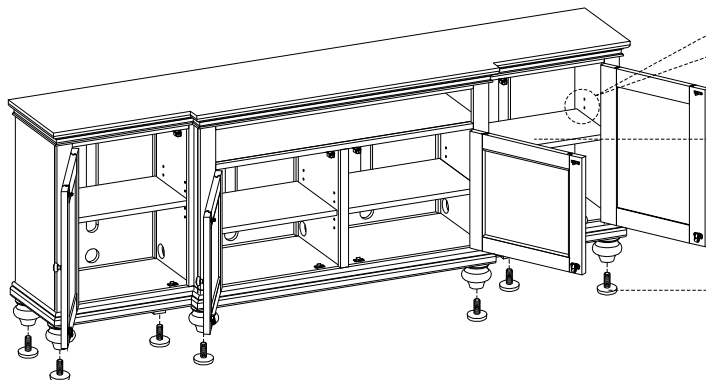

If you prefer to adjust the shelf location, remove the screws and move shelf brackets to the desired location. Then secure the brackets to shelf with screws.

Adjustable wood shelves

Adjust the leveler when necessary

Leveler on Bun feet, Support legs and Back Support

BEFORE USING THIS PRODUCT PLEASE READ, UNDERSTAND, AND FOLLOW THESE INSTRUCTIONS. Save these instructions for future reference.

FOR INDOOR USE ONLY



ITEM NO: I07-284H-WBR/PEP/BLK 86" Hutch

Thank you for purchasing this quality product. Be sure to check all packing material carefully for small parts that may come loose inside the carton during shipment.

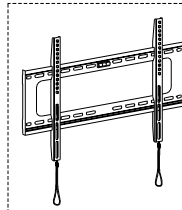
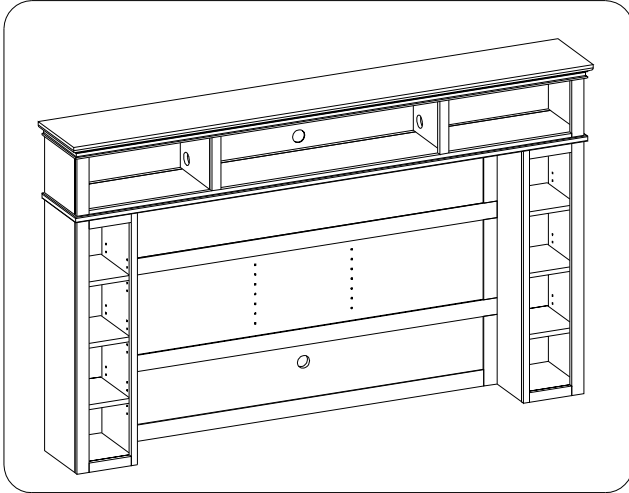

TV Mount

Assembly instructions for the TV mount are in the TV mount package. Follow these instructions when attaching TV mount and TV to the TV frame.

**TOOLS REQUIRED (NOT PROVIDED)**

**PHILLIPS SCREWDRIVER**

**HARDWARE LIST:**

No.	Description	Sketch	Quantity
A	Bolt Ø1/4"*1-1/2"		28 PCS
B	Lock Washer Ø1/4"		28 PCS
C	Flat Washer Ø1/4" *3/4"		28 PCS
D	Allen Wrench 4mm		1 PC
E	Wood Screw		6 PCS

**COMPONENTS LIST:**

No.	Description	Sketch	Quantity
1	Top assembly		1 PC
2	Left side assembly		1 PC
3	Right side assembly		1 PC
4	Top back panel		1 PC
5	Middle back panel		1 PC
6	Bottom back panel		1 PC
7	TV Mount		1 Set

**FUNCTIONALITY INSTRUCTION**

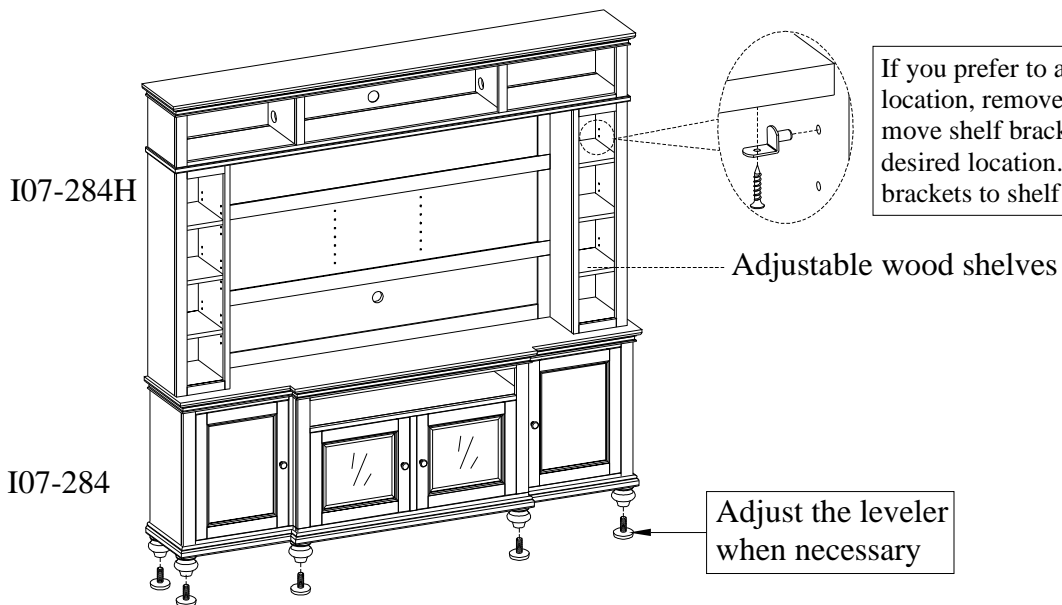

If you prefer to adjust the shelf location, remove the screws and move shelf brackets to the desired location. Then secure the brackets to shelf with screws.

**BEFORE USING THIS PRODUCT PLEASE READ, UNDERSTAND, AND FOLLOW THESE INSTRUCTIONS. Save these instructions for future reference.**

**FOR INDOOR USE ONLY**



ITEM NO: I07-284H-WBR/PEP/BLK 86" Hutch

**STEP 1:** Attach the top back panel and bottom back panel to the middle back panel by using 8 bolts (A), lock washers (B) and flat washers (C).

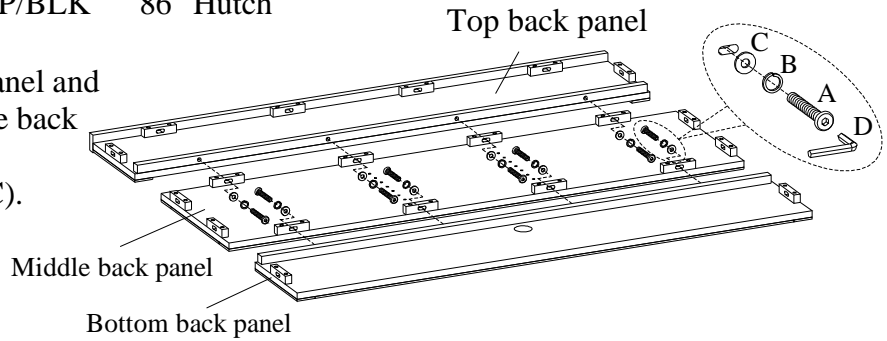

Right side assembly

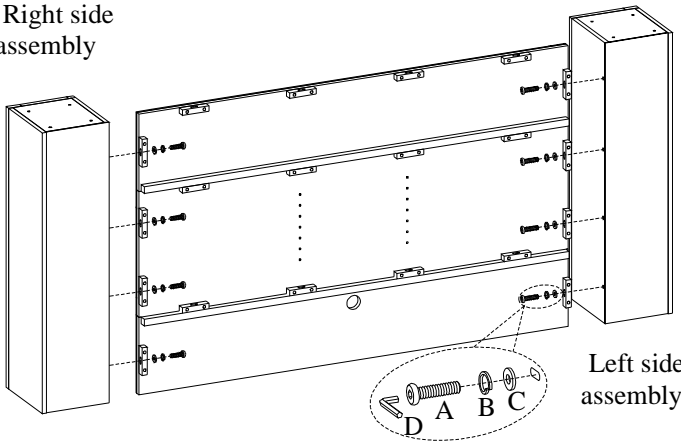

**STEP 2:** Attach the back assembly to the left side assembly and right side assembly by using 8 bolts (A), lock washers (B) and flat washers (C). Do not tighten the bolts completely.

**STEP 3:** Attach the top assembly to the left side assembly, right side assembly and back assembly by using 12 bolts (A), lock washers (B) and flat washers (C). Completely tighten all bolts.

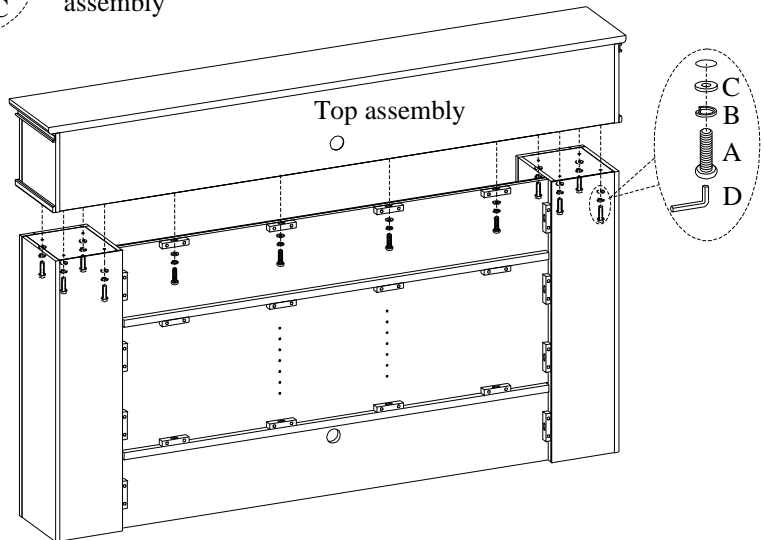

**STEP 4:** Swing large metal plate on the back of hutch into an ideal location as shown to the right. Then re-secure the large metal plate with screw (E) to hutch and console.

