

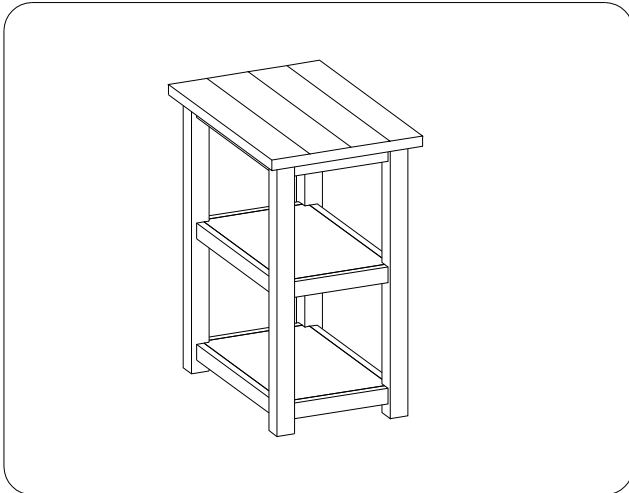

ITEM NO: I221-9130 Chairside Table

Thank you for purchasing this quality product. Be sure to check all packing material carefully for small parts that may come loose inside the carton during shipment.



TOOLS REQUIRED (NOT PROVIDED)			
PHILLIPS SCREWDRIVER			
COMPONENTS LIST:			
No.	Description	Sketch	Quantity
1	Table Top		1 PC
2	Leg		4 PCS
3	Bottom shelf		2 PCS
HARDWARE LIST:			
No.	Description	Sketch	Quantity
A	Bolt Ø1/4"*2"		12 PCS
B	Lock Washer Ø1/4"		12 PCS
C	Flat Washer Ø1/4" *3/4"		12 PCS
D	Allen Wrench 4mm		1 PC

STEP 1: Put the table top face down on a soft surface. Attach the legs to table top by using 4 bolts(A), lock washers(B) and flat washers(C). Do not completely tighten bolts.

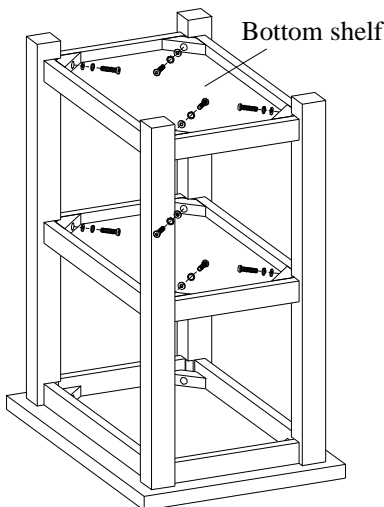
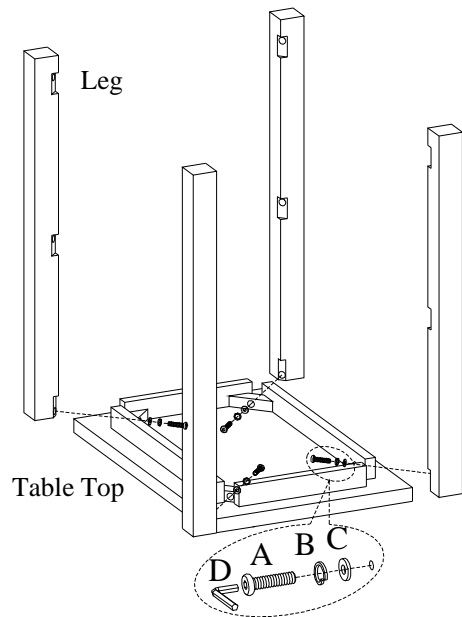

STEP 2: Attach the bottom shelves to legs by using 8 bolts(A), lock washers(B) and flat washers(C). Completely tighten all bolts. Turn the assembled table to the upright position.

BEFORE USING THIS PRODUCT PLEASE READ, UNDERSTAND, AND FOLLOW THESE INSTRUCTIONS. Save these instructions for future reference.

FOR INDOOR USE ONLY