

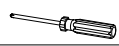















ITEM NO: I287-333 Open Display case

Thank you for purchasing this quality product. Be sure to check all packing material carefully for small parts that may come loose inside the carton during shipment.



TOOLS REQUIRED (NOT PROVIDED)
PHILLIPS SCREWDRIVER 

HARDWARE LIST:			
No.	Description	Sketch	Quantity
A	Bolt Ø1/4" x 3/4"		24 PCS
B	Lock Washer Ø1/4"		24 PCS
C	Flat Washer Ø1/4" x 3/4"		24 PCS
D	Allen Wrench 4mm		1 PC
E	Wood Screw #8 x 3/4"		1 PC

COMPONENTS LIST:			
No.	Description	Sketch	Quantity
1	Left Side Assembly		1 PC
2	Right Side Assembly		1 PC
3	Top Shelf (a)		1 PC
4	Second Shelf (b)		1 PC
5	Third Shelf (c)		1 PC
6	Fourth Shelf (d)		1 PC
7	Bottom Shelf (e)		1 PC
8	Metal Stretcher		2 PCS

### FUNCTIONALITY INSTRUCTION

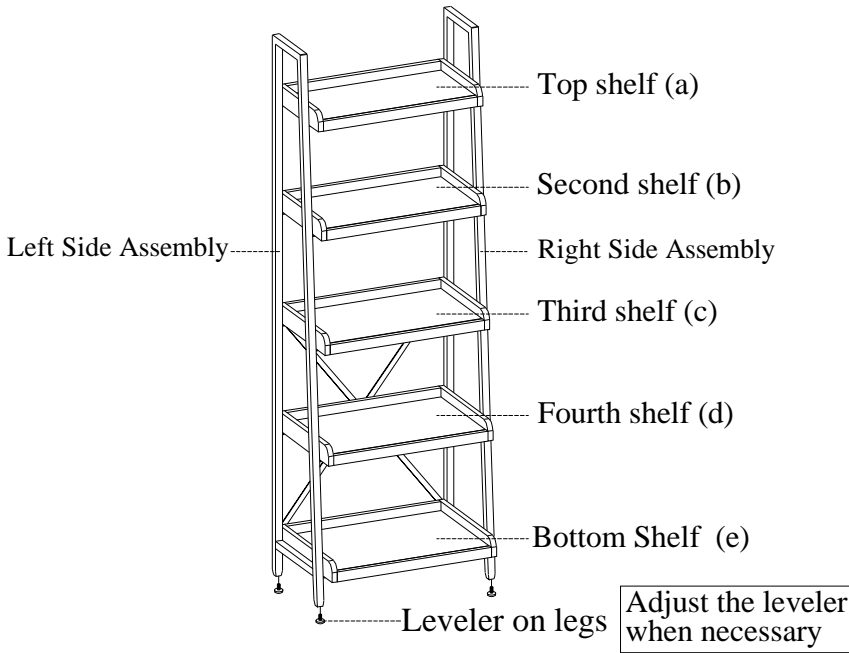

BEFORE USING THIS PRODUCT PLEASE READ, UNDERSTAND, AND FOLLOW THESE INSTRUCTIONS. Save these instructions for future reference.

FOR INDOOR USE ONLY



ITEM NO: I287-333 Open Display case

**STEP 1:** Put the left/right side assembly backside down on a soft surface.

**STEP 2:** Attach the top shelf (a), second shelf (b), third shelf (c), fourth shelf (d) and bottom shelf (e) to left/right side assembly by using 20 bolts(A), lock washers(B) and flat washers(C). Completely tighten all bolts.

**STEP 3:** Turn the assembled case to the upright position.

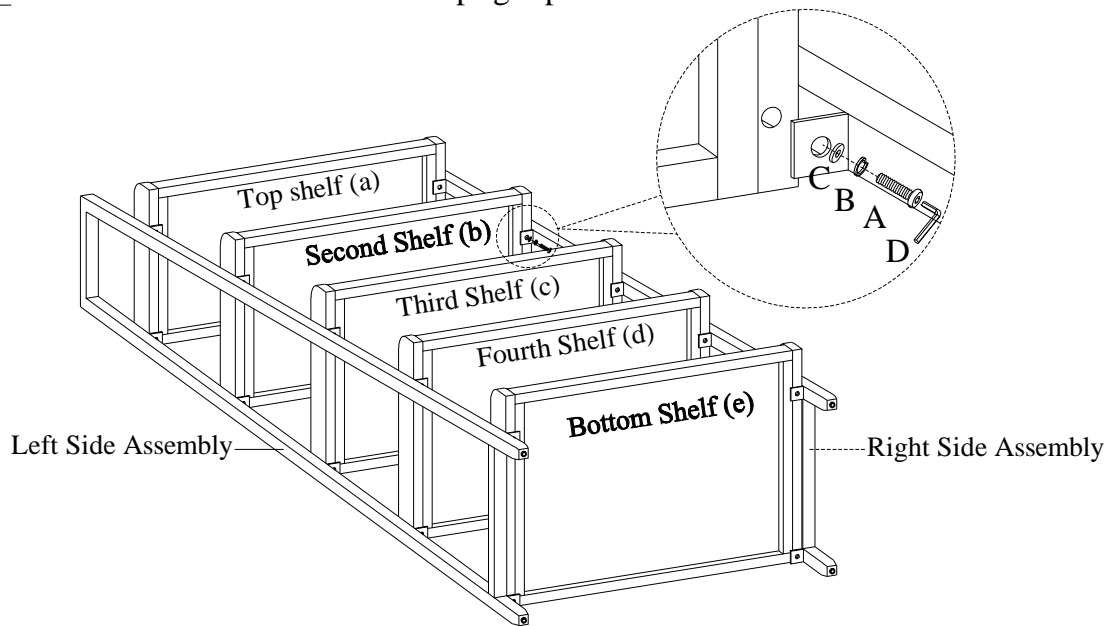

**STEP 4:** Place the metal stretchers on the back of the case assemble by using 4 bolts(A) and 1 wood screw(E), lock washers(B) and flat washers(C). Use the Allen wrench provided to tighten all the bolts.

