

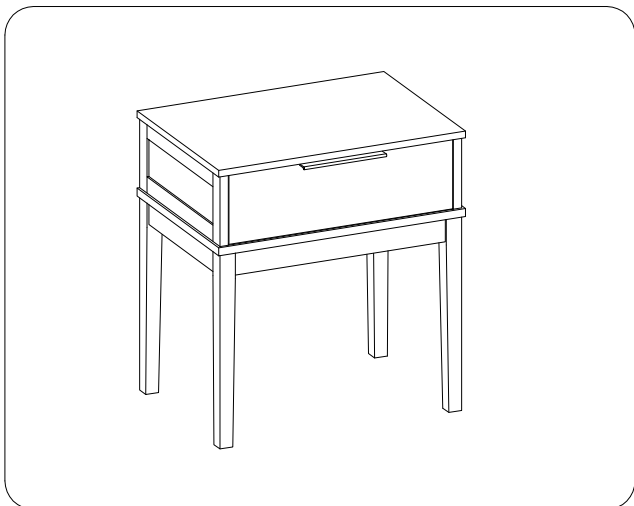

ITEM NO: I3046-451 1 Drawer Nightstand

Thank you for purchasing this quality product. Be sure to check all packing material carefully for small parts that may come loose inside the carton during shipment.

WARNING! Before using this product, please read, understand, and follow these instructions. Failure to follow each of these assembly instructions precisely may result in damage to the product and / or injury to the consumer.



TOOLS REQUIRED (NOT PROVIDED)	
PHILLIPS SCREWDRIVER	

HARDWARE LIST:			
No.	Description	Sketch	Quantity
A	Bolt Ø5/16" x 2-3/16"		8 PCS
B	Lock Washer Ø5/16"		8 PCS
C	Flat Washer Ø5/16" x 3/4"		8 PCS
D	Allen Wrench M4		1 PC

COMPONENTS LIST:			
No.	Description	Sketch	Quantity
1	Case		1 PC
2	Leg		4 PCS

FUNCTIONALITY INSTRUCTION

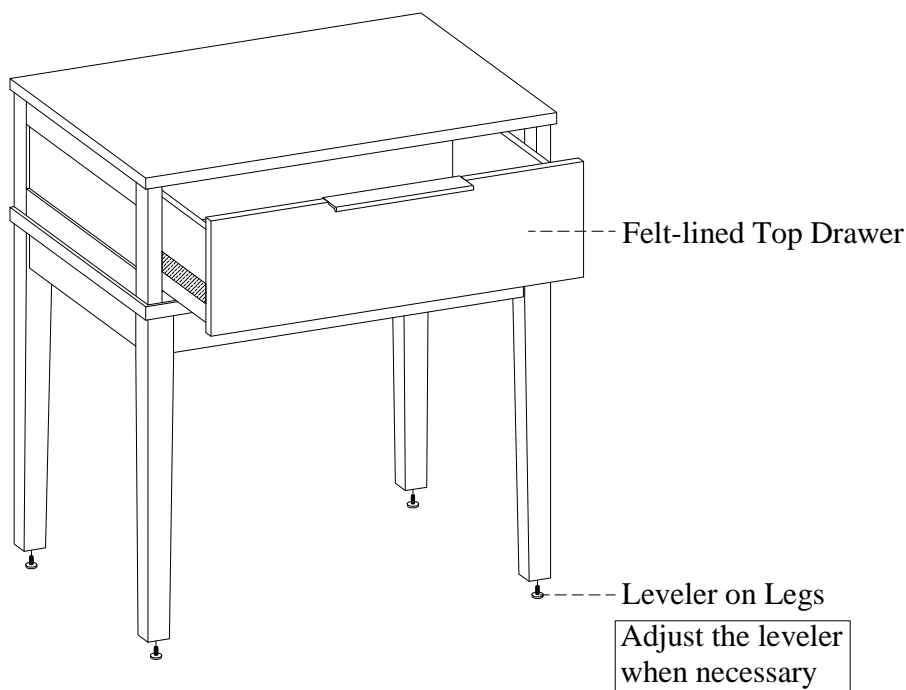

FOR INDOOR USE ONLY



ITEM NO: I3046-451 1 Drawer Nightstand

STEP 1: Put the case face down on a soft surface.

STEP 2: Attach the legs to the case by using 8 bolts (A), lock washers (B) and flat washers (C). Use the Allen wrench (D) provided to tighten all the bolts.

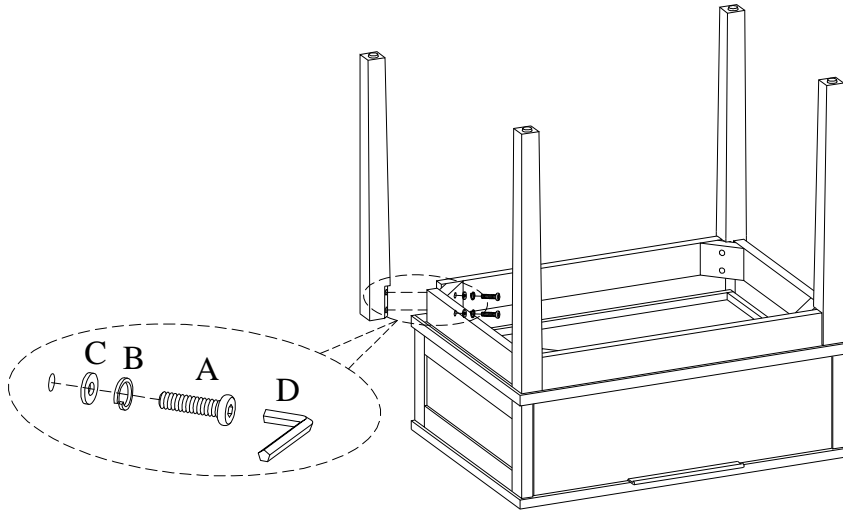

STEP 3: Turn the assembled case to the upright position.

