



ITEM NO: I3327-9150 Sofa Table

Thank you for purchasing this quality product. Be sure to check all packing material carefully for small parts that may come loose inside the carton during shipment.

WARNING! Before using this product, please read, understand, and follow these instructions. Failure to follow each of these assembly instructions precisely may result in damage to the product and / or injury to the consumer.



UNIT SHOULD BE INSTALLED BY 2 OR MORE PERSONS.

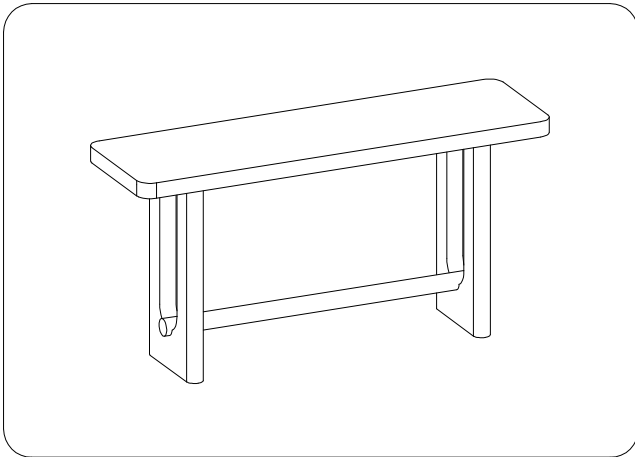

TOOLS REQUIRED (NOT PROVIDED)

PHILLIPS SCREWDRIVER

COMPONENTS LIST:

No.	Description	Sketch	Quantity
A	Bolt Ø5/16" x 1-1/2"		12 PCS
B	Bolt Ø5/16" x 4"		2 PCS
C	Lock Washer Ø5/16"		14 PCS
D	Flat Washer Ø5/16" x 3/4"		14 PCS
E	Allen Wrench 4mm		1 PC

COMPONENTS LIST:

No.	Description	Sketch	Quantity
1	Table Top		1 PC
2	Side Frame		2 PCS
3	Round Stretcher		1 PC

FUNCTIONALITY INSTRUCTION

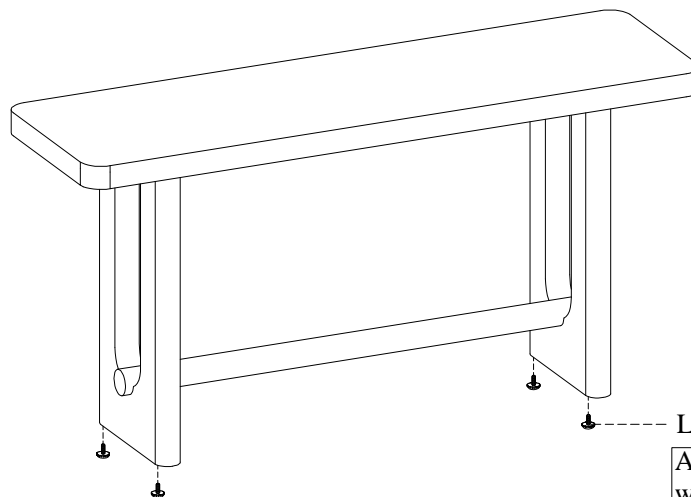

FOR INDOOR USE ONLY



ITEM NO: I3327-9150 Sofa Table

STEP 1: Put the table top upside down on a soft surface.

STEP 2: Attach the side frames to the bottom of table top by using 12 bolts (A), lock washers (C), flat washers (D) with the allen wrench (E). Do not completely tighten bolts.

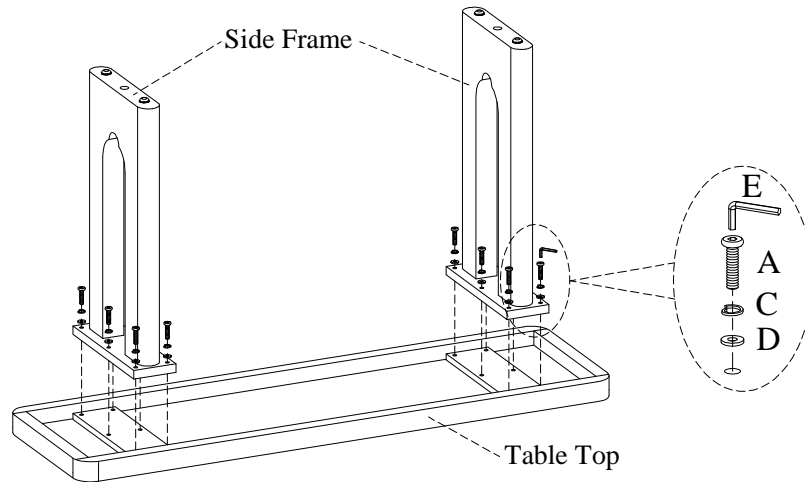

STEP 3: Attach the round stretcher to side frames by using 2 bolts (B), lock washers (C), flat washers (D). Use the Allen wrench provided to completely tighten all the bolts.

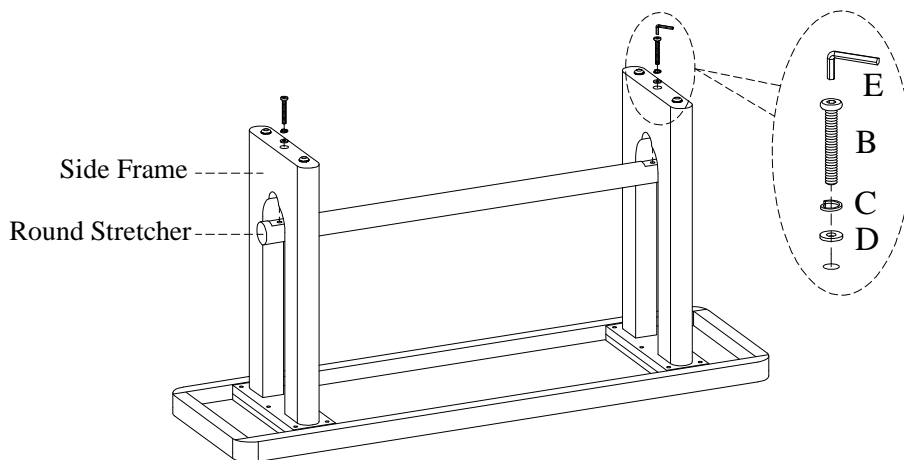

STEP 4: Return the assembled table to the upright position.

