



ITEM NO: I34-453-SNA Dresser

Thank you for purchasing this quality product. Be sure to check all packing material carefully for small parts that may come loose inside the carton during shipment.



TOOLS REQUIRED (NOT PROVIDED)			
PHILLIPS SCREWDRIVER			
COMPONENTS LIST:			
No.	Description	Sketch	Quantity
1	Case		1 PC
2	Leg		4 PCS
3	Support Leg		1 PC
HARDWARE LIST:			
No.	Description	Sketch	Quantity
A	Bolt Ø5/16" x 1-3/4"		8 PCS
B	Lock Washer Ø5/16"		8 PCS
C	Flat Washer Ø5/16" *5/8"		8 PCS
D	Allen Wrench 4mm		1 PC

STEP 1: Put the case upside down on a soft surface, Attach the legs and support leg to the bottom of case by using 8 bolts(A), lock washers(B) and flat washers(C). Return the case to the upright position.

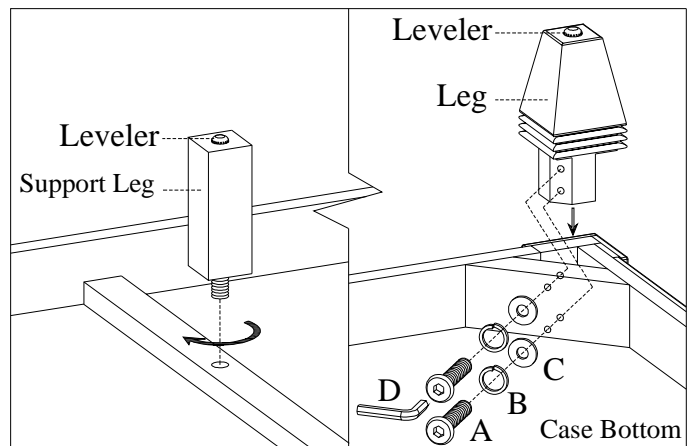

FUNCTIONALITY INSTRUCTION

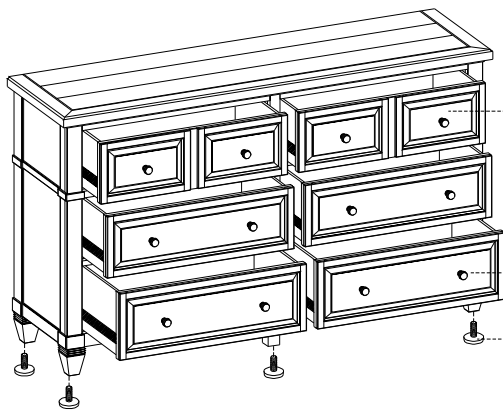

Felt-lined Top Drawers

Cedar-lined Bottom Drawers

Leveler on Legs & Support Leg

Adjust the leveler when necessary

BEFORE USING THIS PRODUCT PLEASE READ, UNDERSTAND, AND FOLLOW THESE INSTRUCTIONS. Save these instructions for future reference.

FOR INDOOR USE ONLY