



ITEM NO: I629-9140-DEN/PRW End Table





Thank you for purchasing this quality product. Be sure to check all packing material carefully for small parts that may come loose inside the carton during shipment.





TOOLS REQUIRED (NOT PROVIDED)

PHILLIPS SCREWDRIVER 

HARDWARE LIST:

No.	Description	Sketch	Quantity
A	Bolt Ø1/4" x 1-3/4" (20)		10 PCS
B	Lock Washer Ø1/4"		10 PCS
C	Flat Washer Ø1/4" x 3/4"		10 PCS
D	Allen Wrench 4mm		1 PC

COMPONENTS LIST:

No.	Description	Sketch	Quantity
1	Table Top		1 PC
2	Side Assembly		2 PCS
3	Bottom Shelf		1 PC

FUNCTIONALITY INSTRUCTION

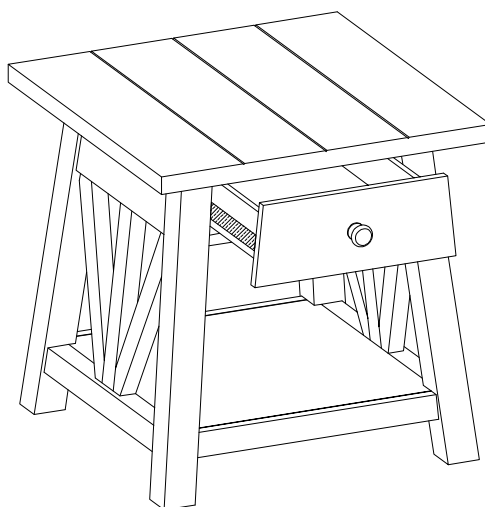

BEFORE USING THIS PRODUCT PLEASE READ, UNDERSTAND, AND FOLLOW THESE INSTRUCTIONS.

Save these instructions for future reference.

FOR INDOOR USE ONLY



ITEM NO: I629-9140-DEN/PRW End Table

STEP 1: Put the table top face down on a soft surface. Pull out the drawer. Attach the side assemblies to table top by using 6 bolts(A), lock washers(B) and flat washers(C). Do not completely tighten bolts.

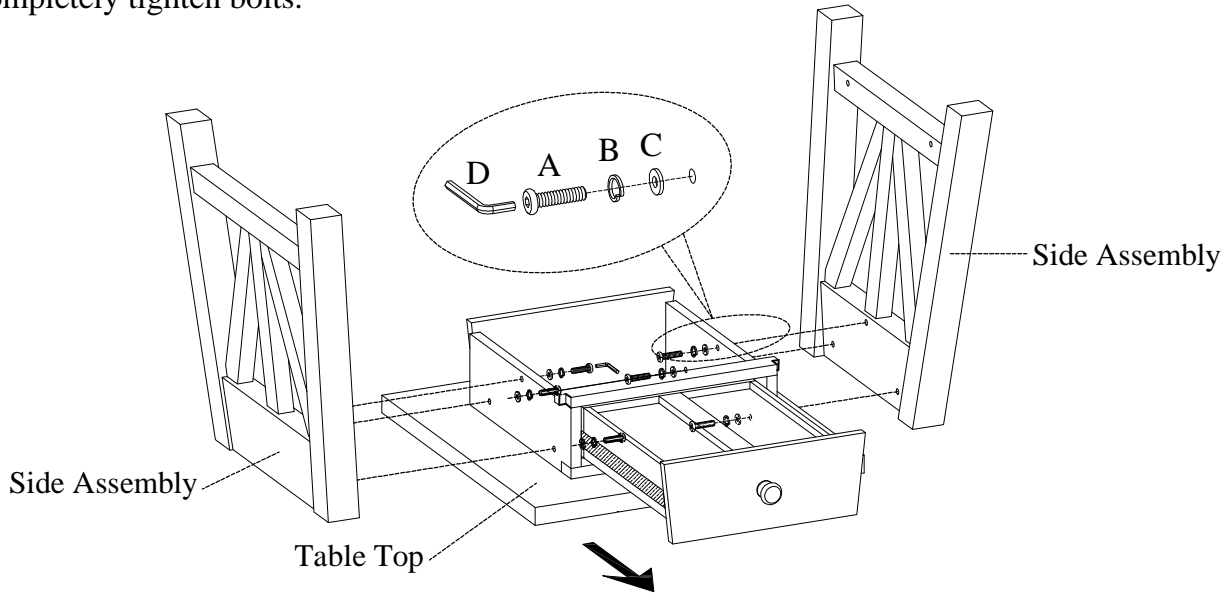

STEP 2: Attach the bottom shelf to side assemblies by using 4 bolts(A), lock washers(B) and flat washers(C). Use the Allen wrench provided to tighten all the bolts. Push back the drawer. Turn the assembled table to the upright position.

