

ITEM NO: I644-280 80" Console

Thank you for purchasing this quality product. Be sure to check all packing material carefully for small parts that may come loose inside the carton during shipment.

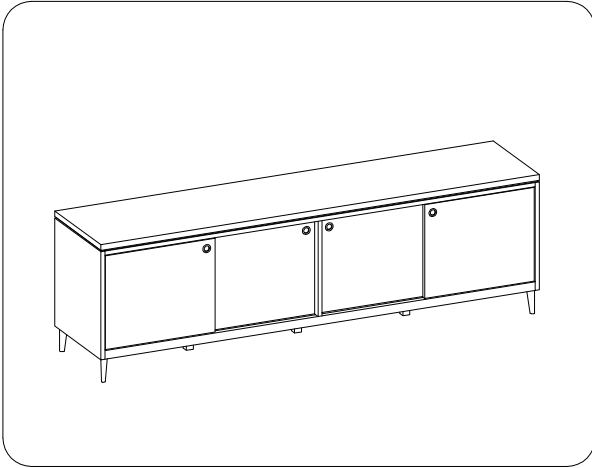

TOOLS REQUIRED (NOT PROVIDED)

PHILLIPS SCREWDRIVER

HARDWARE LIST:

No.	Description	Sketch	Quantity
A	Bolt Ø5/16" x 1"		12 PCS
B	Lock Washer Ø5/16"		12 PCS
C	Flat Washer Ø5/16" x 3/4"		12 PCS
D	Allen Wrench 4mm		1 PC

COMPONENTS LIST:

No.	Description	Sketch	Quantity
1	Case		1 PC
2	Metal Leg		4 PCS
3	Support Leg		3 PCS

FUNCTIONALITY INSTRUCTION

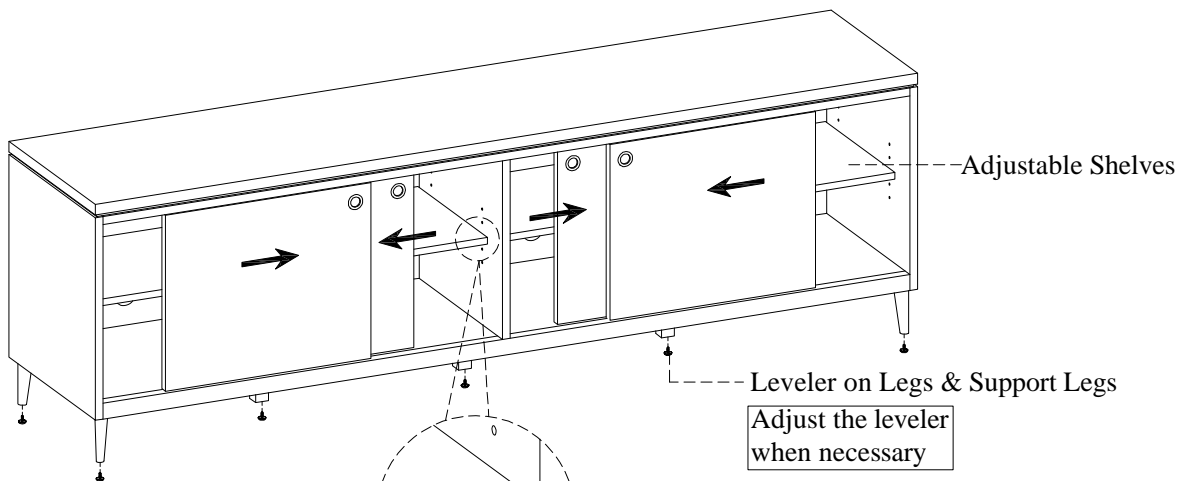

If you prefer to adjust the shelf location, remove the screws and move shelf brackets to the desired location. Then secure the brackets to shelf with screws.

BEFORE USING THIS PRODUCT PLEASE READ, UNDERSTAND, AND FOLLOW THESE INSTRUCTIONS. Save these instructions for future reference.

FOR INDOOR USE ONLY

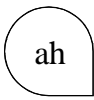

ITEM NO: I644-280 80" Console

STEP 1: Put the case upside down on a soft surface.

STEP 2: Attach the metal legs by using 12 bolts (A), lock washers (B) and flat washers (C). Use the allen wrench (D) to tighten all bolts. Return the console to the upright position.

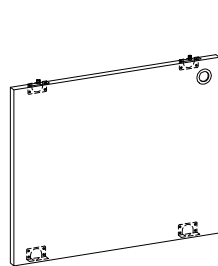
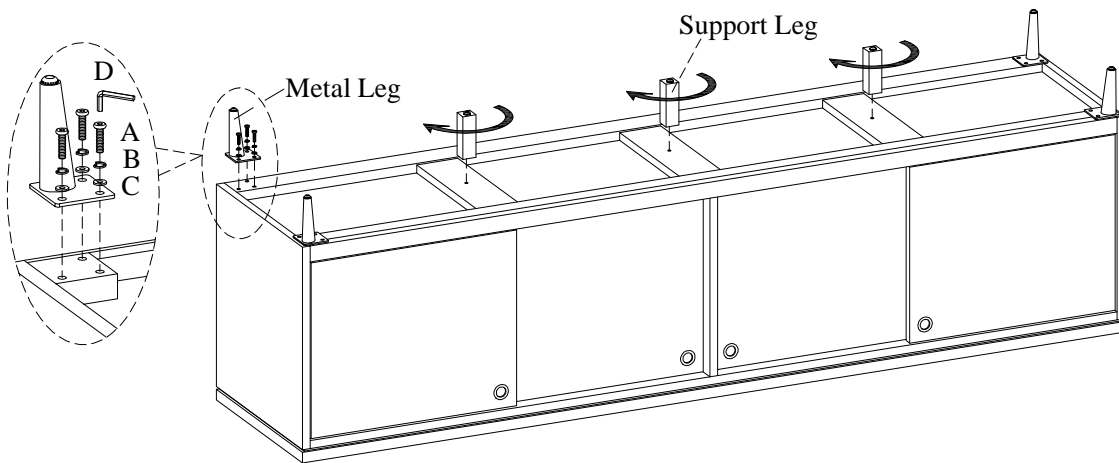

Slide Door-Left

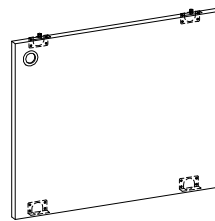

Slide Door-Right

INSTALL THE SLIDE DOORS:

Push the guide pins down so they are inside the door. Place the roller on the metal track so the door rolls smoothly. Place the top of the door underneath the track so when you push the release button the pins go up in to the track as shown below.

REMOVE THE SLIDE DOORS(if necessary):

Press and lower the release buttons on the back of the door to lower the guide pins as shown below. Then remove the door.

Adjust here to adjust the roller up or down

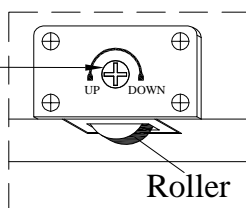

Roller

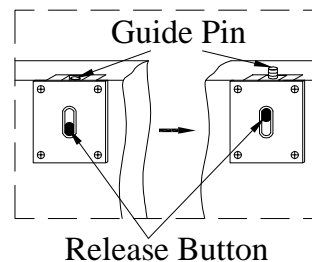

Release Button

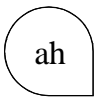

ITEM NO: I644-280B TV Backer Panel

Thank you for purchasing this quality product. Be sure to check all packing material carefully for small parts that may come loose inside the carton during shipment.

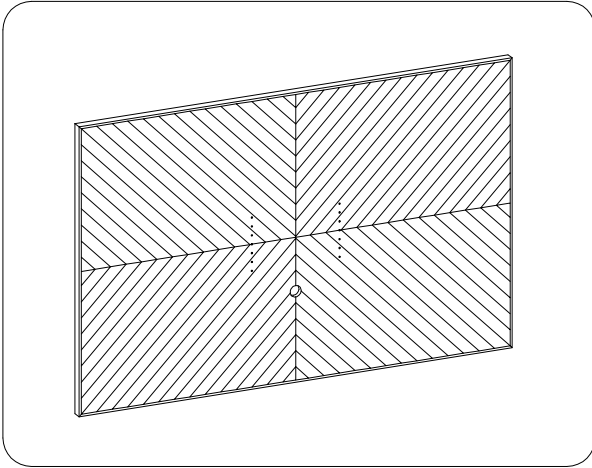

TOOLS REQUIRED (NOT PROVIDED)

PHILLIPS SCREWDRIVER

HARDWARE LIST:

No.	Description	Sketch	Quantity
A	Bolt Ø5/16" x 1-1/2"		8 PCS
B	Bolt Ø5/16" x 2"		8 PCS
C	Lock Washer Ø5/16"		16 PCS
D	Flat Washer Ø5/16" x 3/4"		16 PCS
E	Allen Wrench 4mm		1 PC

COMPONENTS LIST:

No.	Description	Sketch	Quantity
1	TV Backer		1 PC
2	Metal Strip		4 PCS

FUNCTIONALITY INSTRUCTION

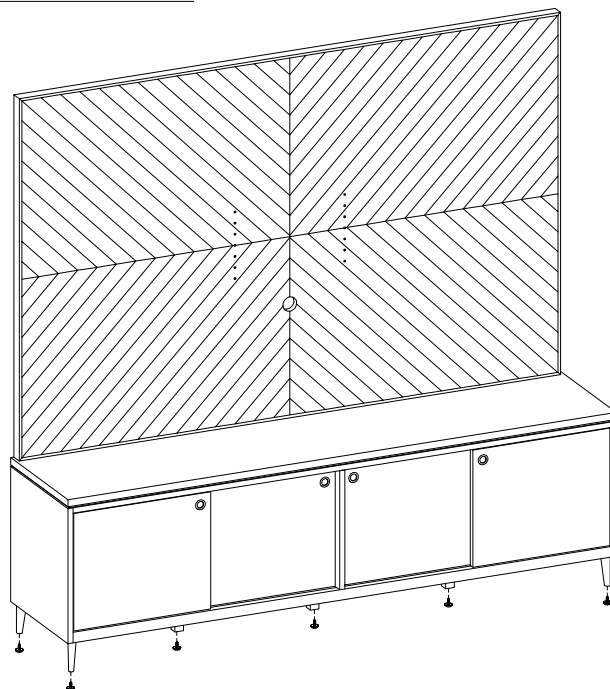

Leveler on Legs
& Support Legs

Adjust the leveler
when necessary

BEFORE USING THIS PRODUCT PLEASE READ, UNDERSTAND, AND FOLLOW THESE INSTRUCTIONS.
Save these instructions for future reference.

FOR INDOOR USE ONLY

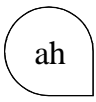

ITEM NO: I644-280B TV Backer Panel

STEP 1: Attach the metal strips to the console by using 8 bolts (B), lock washers (C), and flat washers (D) with an allen wrench (E). Do not tighten bolts completely.

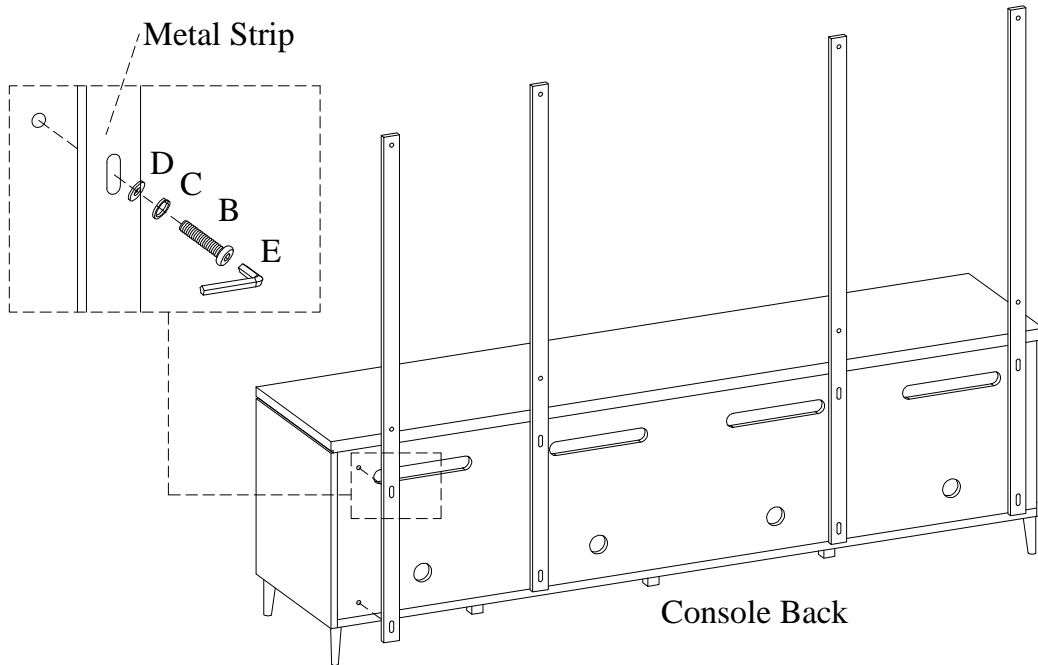

STEP 2: Attach the metal strips to the TV backer by using 8 bolts(A), lock washers(C), and flat washers(D). Tighten all bolts on console and TV backer with Allen wrench.

