

ITEM NO: I644-366WD 68" Writing Desk

Thank you for purchasing this quality product. Be sure to check all packing material carefully for small parts that may come loose inside the carton during shipment.

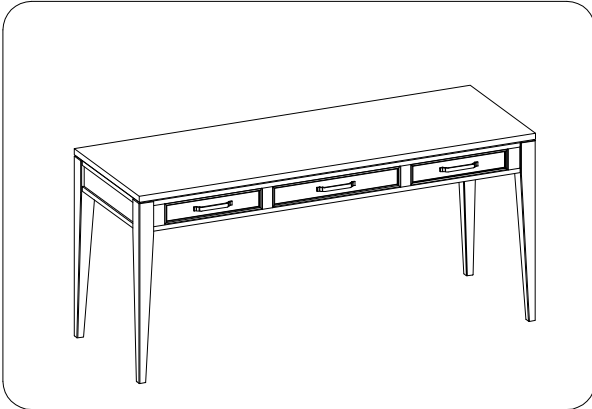

TOOLS REQUIRED (NOT PROVIDED)

PHILLIPS SCREWDRIVER

HARDWARE LIST:

No.	Description	Sketch	Quantity
A	Bolt Ø5/16" x 2-1/4"		8 PCS
B	Lock Washer Ø5/16"		8 PCS
C	Flat Washer Ø5/16" x 3/4"		8 PCS
D	Allen Wrench 4mm		1 PC

COMPONENTS LIST:

No.	Description	Sketch	Quantity
1	Desk Top		1 PC
2	Leg		4 PCS

FUNCTIONALITY INSTRUCTION

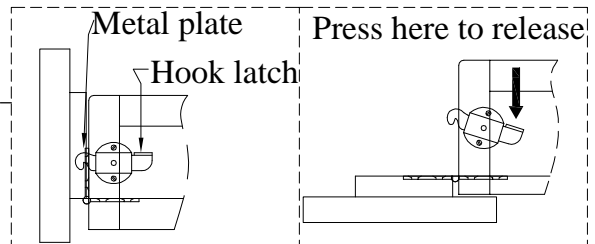
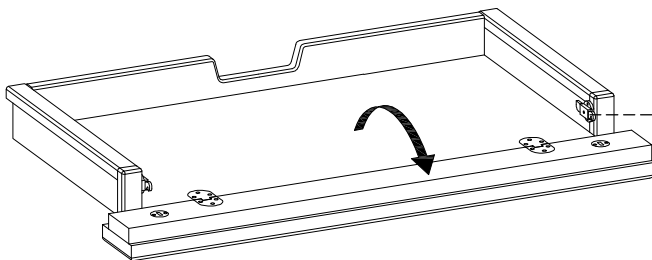
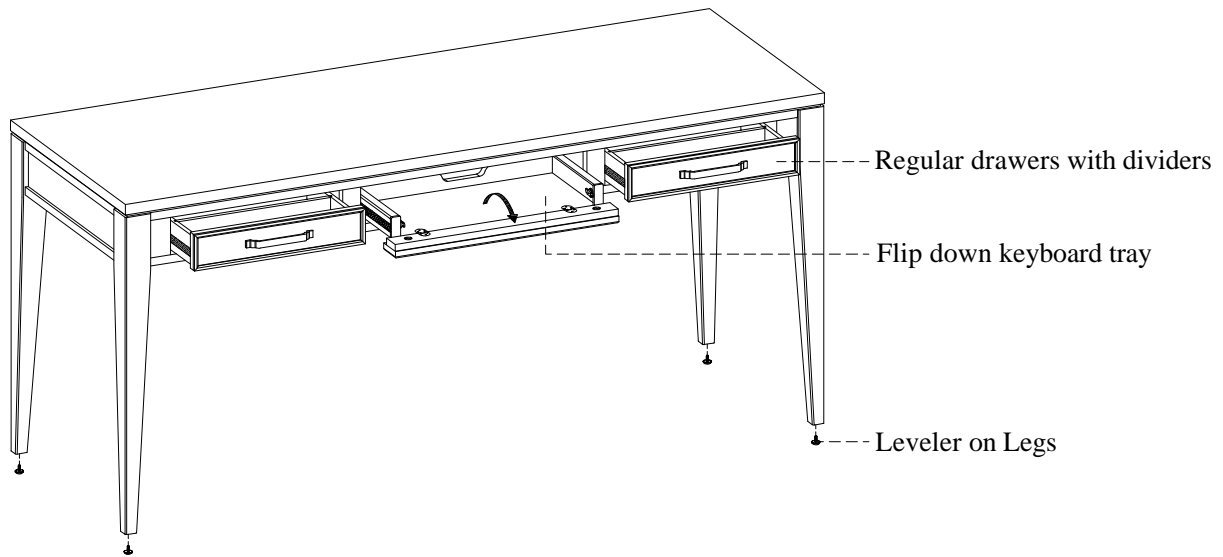

BEFORE USING THIS PRODUCT PLEASE READ, UNDERSTAND, AND FOLLOW THESE INSTRUCTIONS. Save these instructions for future reference.

FOR INDOOR USE ONLY

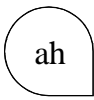

ITEM NO: I644-366WD 68" Writing Desk

To dis-assemble desk (If necessary):

STEP 1: Remove the side drawers from the desk: Fully extend the drawer, then press the plastic tab down on the right and up on the left at the same time as shown below. While holding the tabs pressed down/up, pull the drawer out.

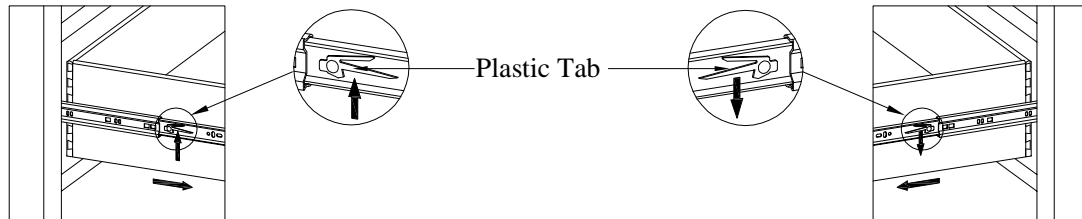

STEP 2: Put the desk top upside down on a soft surface.

STEP 3: Attach the legs by using 8 bolts (A), lock washers (B) and flat washers (C) as shown below. Use the allen wrench (D) to tighten all bolts. Return the desk to the upright position.

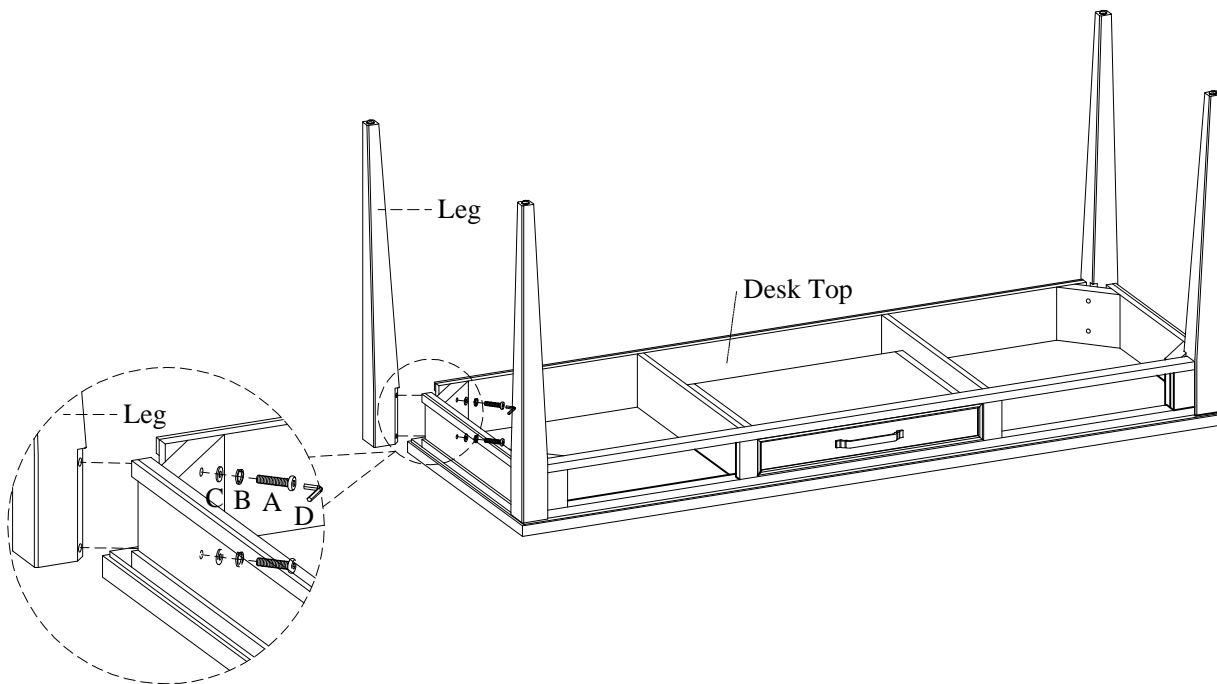

STEP 4: Replace all of the drawers in desk: Fully extend the slides from the desk. Then align the slides on the drawer to the slides on the case as shown right. Push the drawer back in. You may have to slide the drawer in and out several times in order to properly align the ball bearings.

