

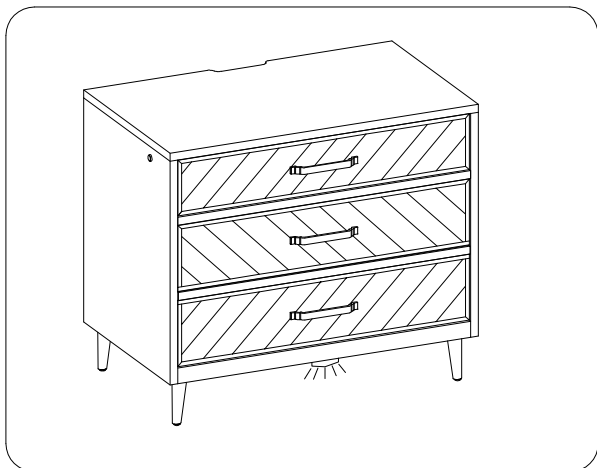

ITEM NO: I644-449 Liv360 Nightstand

Thank you for purchasing this quality product. Be sure to check all packing material carefully for small parts that may come loose inside the carton during shipment.



TOOLS REQUIRED (NOT PROVIDED)	
PHILLIPS SCREWDRIVER	

HARDWARE LIST:			
No.	Description	Sketch	Quantity
A	Bolt Ø5/16" x 1"		12 PCS
B	Lock Washer Ø5/16"		12 PCS
C	Flat Washer Ø5/16" x 3/4"		12 PCS
D	Allen Wrench 4mm		1 PC

COMPONENTS LIST:			
No.	Description	Sketch	Quantity
1	Case		1 PC
2	Metal Leg		4 PCS

FUNCTIONALITY INSTRUCTION

2 AC outlet Power Pack

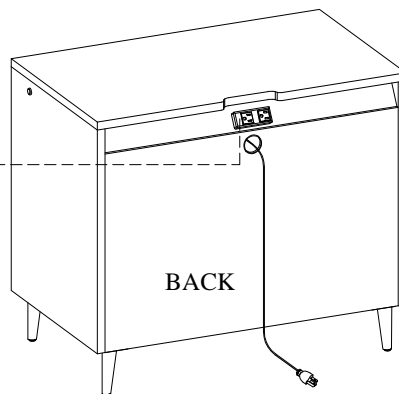

BACK

Touch Switch
Touch the touch switch to turn on/off or adjust the lighting.

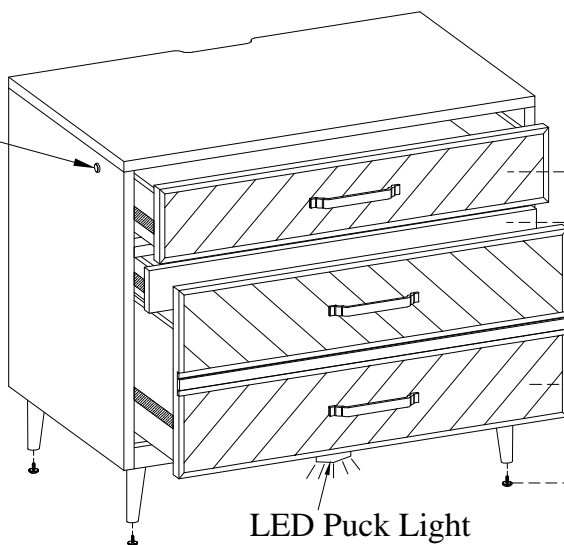

Felt-lined Top Drawer

Felt-lined Hidden Drawer

Cedar-lined Bottom Drawer

LED Puck Light

Leveler on Legs
Adjust the leveler when necessary

BEFORE USING THIS PRODUCT PLEASE READ, UNDERSTAND, AND FOLLOW THESE INSTRUCTIONS. Save these instructions for future reference.

FOR INDOOR USE ONLY

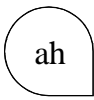

ITEM NO: I644-449 Liv360 Nightstand

STEP 1: Put the case upside down on a soft surface.

STEP 2: Attach the metal legs by using 12 bolts (A), lock washers (B) and flat washers (C).
Use the allen wrench (D) to tighten all bolts.

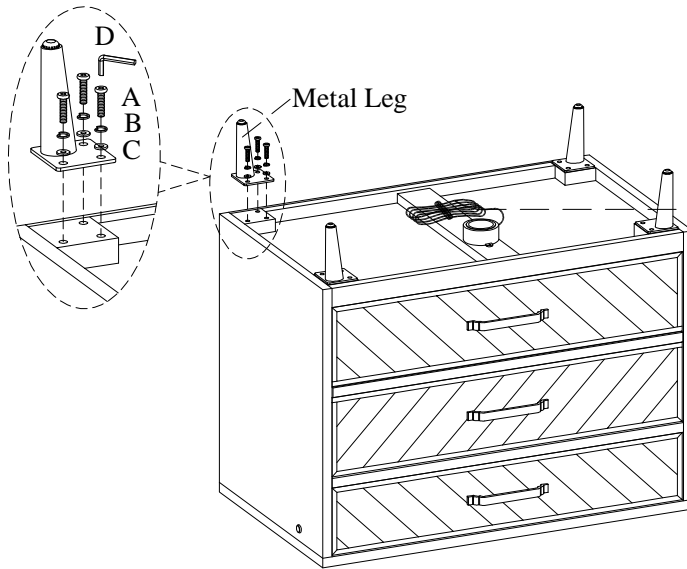

Remove the power cord from the bottom of the case, remove the twist ties.

STEP 3: Return the case to the upright position.

